

ITEM NO.	PART NUMBER	DESCRIPTION	QTY.
1	prrsa	Shank Assembly	1
2	prrha	Hopper Assembly	1
3	prrf	Frame	1
4	prrjs	Jack Stand	2
5	prrca	Coulter Assembly	1
6	p1x2sp	8" Cat I & Cat II Step Pin	2
7	pr40x52rc	#40 x 52" L Roller Chain	1
8	prrsdt	Square Drop Tube Mount	1
9	prrsp	Shank Point	1
10	prrwa	Wheel Assembly	1

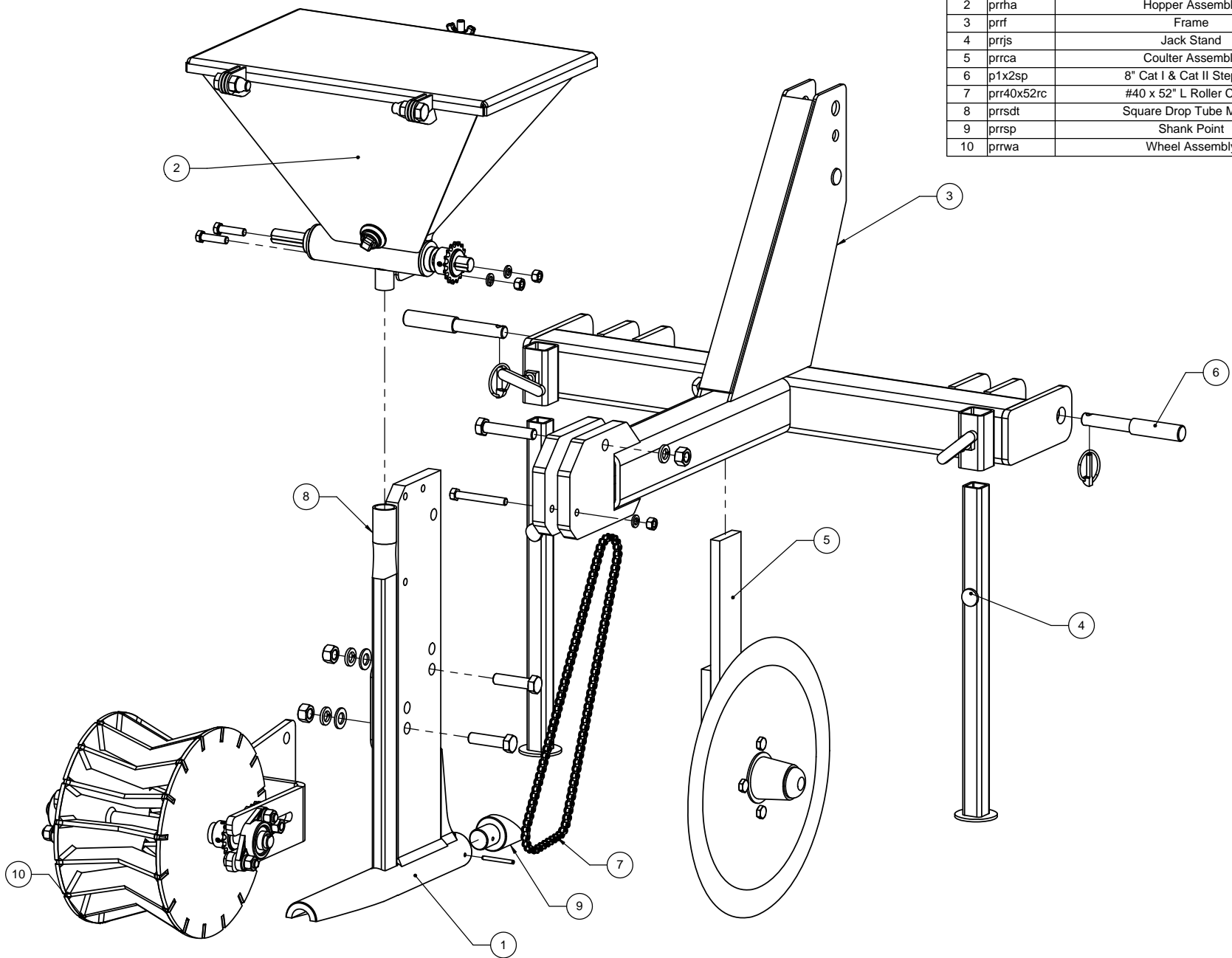

PROPRIETARY AND CONFIDENTIAL
 THE INFORMATION CONTAINED IN THIS
 DRAWING IS THE SOLE PROPERTY OF
 ArmstrongAg. ANY
 REPRODUCTION IN PART OR AS A WHOLE
 WITHOUT THE WRITTEN PERMISSION OF
 ArmstrongAg IS
 PROHIBITED.

		UNLESS OTHERWISE SPECIFIED:	NAME	DATE	ArmStrongAg	
		DIMENSIONS ARE IN INCHES	DRAWN		TITLE:	
		TOLERANCES:	CHECKED		Rodent Ridder	
		FRACTIONAL: ±	ENG APPR		Assembly	
		ANGULAR: MACH ± BEND ±	MFG APPR		SIZE DWG. NO. REV	
		TWO PLACE DECIMAL: ±	D/A		C RR Assembly 1	
		THREE PLACE DECIMAL: ±	COMMENTS:		SCALE: 1:5 WEIGHT: 460.34 SHEET 1 OF 2	
		INTERPRET GEOMETRIC TOLERANCING PER:				
		MATERIAL:				
NEXT ASSY	USED ON	FINISH				
APPLICATION		DO NOT SCALE DRAWING				

ITEM NO.	PART NUMBER	DESCRIPTION	QTY.
1	prrh	Hopper	1
2	prrm	Meter	1
3	prrds	40P 17T Sprocket	1
4	prrhdp	Hopper Drain Plug	1
5	prrl	Lid	1
6	prrmc	Meter Collar	2

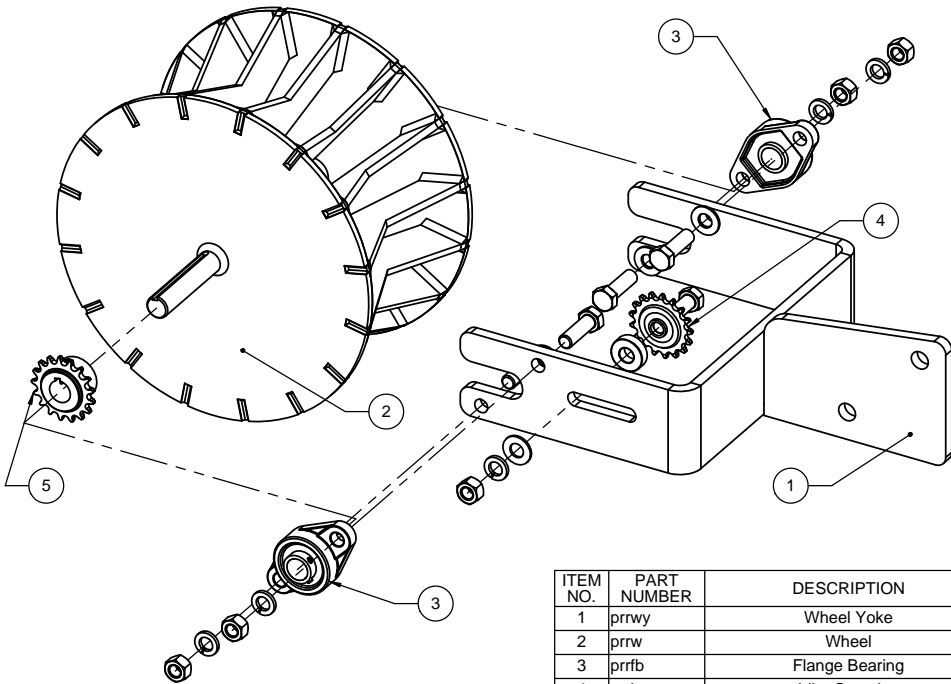
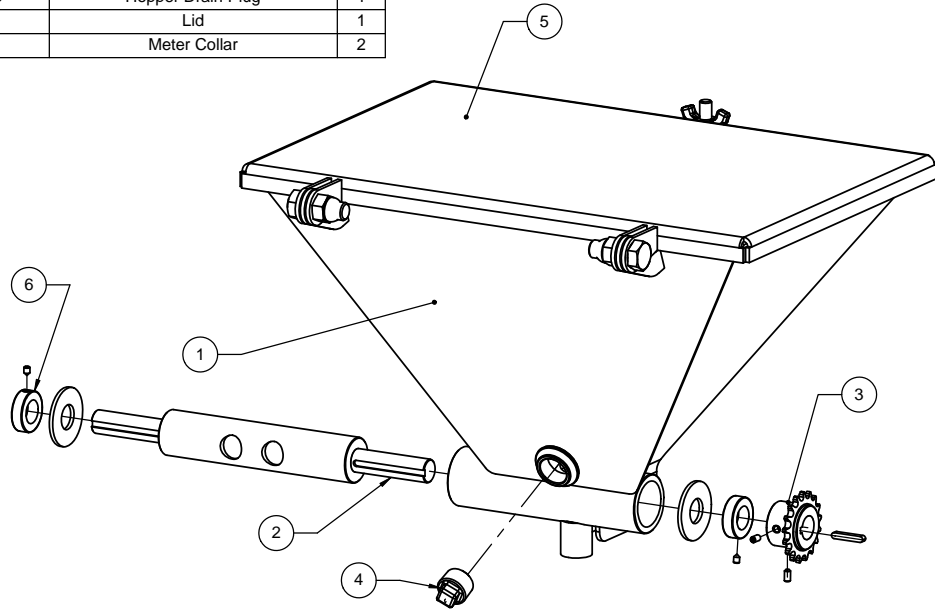

ITEM NO.	PART NUMBER	DESCRIPTION	QTY.
1	prrwy	Wheel Yoke	1
2	prrw	Wheel	1
3	prrfb	Flange Bearing	2
4	prris	Idler Sprocket	1
5	prrds	40P 17T Sprocket	1

ITEM NO.	PART NUMBER	DESCRIPTION	QTY.
1	prrc	Coulter	1
2	prrcs	Coulter Shank	1
3	prrha	Hub Assembly	1

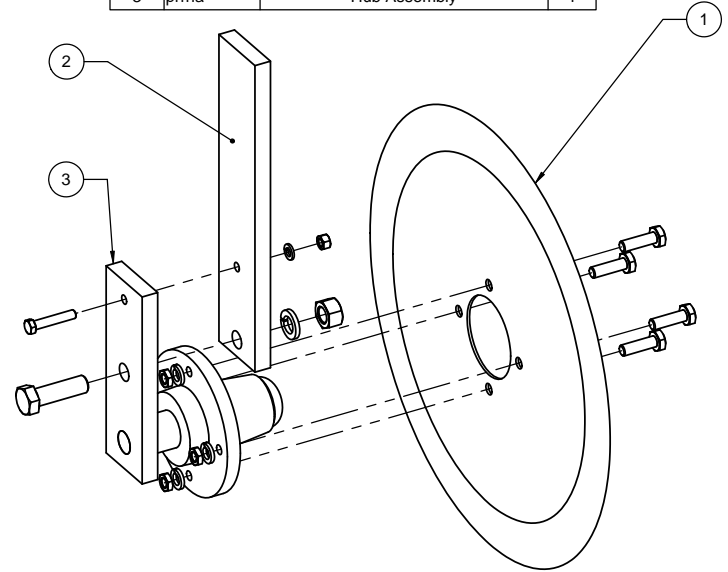

PROPRIETARY AND CONFIDENTIAL
 THE INFORMATION CONTAINED IN THIS DRAWING IS THE SOLE PROPERTY OF ArmstrongAg. ANY REPRODUCTION IN PART OR AS A WHOLE WITHOUT THE WRITTEN PERMISSION OF ArmstrongAg IS PROHIBITED.

		UNLESS OTHERWISE SPECIFIED:	NAME	DATE
		DIMENSIONS ARE IN INCHES	DRAWN	
		TOLERANCES:	CHECKED	
		FRACTIONAL: ±	ENG APPR	
		ANGULAR: MACH ± BEND ±	MFG APPR	
		TWO PLACE DECIMAL ±	D.A.	
		THREE PLACE DECIMAL ±	COMMENTS:	
		INTERPRET GEOMETRIC TOLERANCING PER:		
		MATERIAL:		
		FINISH:		
NEXT ASSY	USED ON	APPLICATION		
		DO NOT SCALE DRAWING		

ArmStrongAg			
TITLE: Rodent Ridder Assembly			
SIZE	DWG. NO.	REV	
C	RR Assembly	1	
SCALE: 1:4	WEIGHT: -	SHEET 2 OF 2	